



The Infinite Bandwidth Company™

# MIC7111

## 1.8V IttyBitty™ Rail-to-Rail Input/Output Op Amp

### Final Information

### General Description

The MIC7111 is a micropower operational amplifier featuring rail-to-rail input and output performance in Micrel's IttyBitty™ SOT-23-5 package. The MIC7111 is ideal for systems where small size is a critical consideration.

The MIC7111 is designed to operate from 1.8V to 11V power supplies.

The MIC7111 benefits small battery operated portable electronic devices where small size and the ability to place the amplifier close to the signal source are primary design concerns.

For other package options, please contact the factory.

### Features

- Small footprint SOT-23-5 package
- Guaranteed performance at 1.8V, 2.7V, 5V, and 10V
- 15µA typical supply current at 1.8V
- 25kHz gain-bandwidth at 5V
- Output swing to within 1mV of rails with 1.8V supply and 100kΩ load
- Suitable for driving capacitive loads

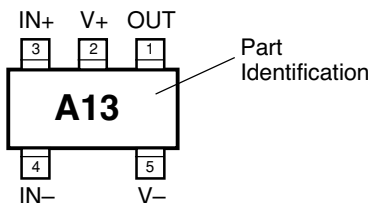
### Applications

- Wireless and cellular communications
- GaAs RF amplifier bias amplifier
- Current sensing for battery chargers
- Reference voltage buffer
- Transducer linearization and interface
- Portable computing

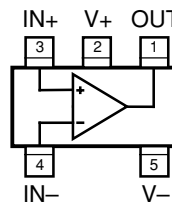
### Ordering Information

Part Number		Junction Temp. Range	Package
Standard	Pb-free		
MIC7111BM5	MIC7111YM5	-40°C to +85°C	SOT-23-5

### Pin Configuration



### Functional Configuration



SOT-23-5 (M5)

### Pin Description

Pin Number	Pin Name	Pin Function
1	OUT	Amplifier Output
2	V+	Positive Supply
3	IN+	Noninverting Input
4	IN-	Inverting Input
5	V-	Negative Supply

IttyBitty is a trademark of Micrel, Inc.

**Absolute Maximum Ratings (Note 1)**

Supply Voltage ( $V_{V+} - V_{V-}$ )	12V
Differential Input Voltage ( $V_{IN+} - V_{IN-}$ )	$\pm(V_{V+} - V_{V-})$
I/O Pin Voltage ( $V_{IN}, V_{OUT}$ ), <b>Note 2</b>	$V_{V+} + 0.3V$ to $V_{V-} - 0.3V$
Junction Temperature ( $T_J$ )	+150°C
Storage Temperature	-65°C to +150°C
Lead Temperature (soldering, 10 sec.)	260°C
ESD, <b>Note 5</b>	2kV

**Operating Ratings (Note 1)**

Supply Voltage ( $V_{V+} - V_{V-}$ )	1.8V to 11V
Junction Temperature ( $T_J$ )	-40°C to +85°C
Max. Junction Temperature ( $T_{J(max)}$ ), <b>Note 3</b>	+85°C
Package Thermal Resistance ( $\theta_{JA}$ ), <b>Note 4</b>	325°C/W
Max. Power Dissipation	<b>Note 3</b>

**DC Electrical Characteristics (1.8V)**

$V_{V+} = +1.8V$ ,  $V_{V-} = 0V$ ,  $V_{CM} = V_{OUT} = V_{V+}/2$ ;  $R_L = 1M$ ;  $T_J = 25^\circ C$ , **bold** values indicate  $-40^\circ C \leq T_J \leq +85^\circ C$ ; unless noted

Symbol	Parameter	Condition	Min	Typ	Max	Units
$V_{OS}$	Input Offset Voltage			0.9	7 <b>9</b>	mV mV
$TCV_{OS}$	Input Offset Voltage Temperature Drift			2.0		$\mu V/^\circ C$
$I_B$	Input Bias Current			1	10 <b>500</b>	pA pA
$I_{OS}$	Input Offset Current			0.01	0.5 <b>75</b>	pA pA
$R_{IN}$	Input Resistance			>10		$T\Omega$
+PSRR	Positive Power Supply Rejection Ratio	$1.8V \leq V_{V+} \leq 5V$ , $V_{V-} = 0V$ , $V_{CM} = V_{OUT} = 0.9V$	60	85		dB
-PSRR	Negative Power Supply Rejection Ratio	$-1.8V \leq V_{V-} \leq -5V$ , $V_{V+} = 0V$ , $V_{CM} = V_{OUT} = -0.9V$	60	85		dB
CMRR	Common-Mode Rejection Ratio	$V_{CM} = -0.2V$ to $+2.0V$	50	70		dB
$C_{IN}$	Common Mode Input Capacitance			3		pF
$V_{OUT}$	Output Voltage Swing	output high, $R_L = 100k$ , specified as $V_{V+} - V_{OUT}$		0.14	1 <b>1</b>	mV mV
		output low, $R_L = 100k$		0.14	1 <b>1</b>	mV mV
		output high, $R_L = 2k$ , specified as $V_{V+} - V_{OUT}$		6.8	23 <b>34</b>	mV mV
		output low, $R_L = 2k$		6.8	23 <b>34</b>	mV mV
$I_{SC}$	Output Short Circuit Current <b>Note 6</b>	sourcing, $V_{OUT} = 0V$	15	25		mA
		sinking, $V_{OUT} = 1.8V$	15	25		mA
$A_{VOL}$	Voltage Gain	sourcing		400		V/mV
		sinking		400		V/mV
$I_s$	Supply Current	$V_{V+} = 1.8V$ , $V_{OUT} = V_{V+}/2$		15	35	$\mu A$

**AC Electrical Characteristics (1.8V)**

$V_+ = +1.8V$ ,  $V_- = 0V$ ,  $V_{CM} = V_{OUT} = V_{V+}/2$ ;  $R_L = 1M$ ;  $T_J = 25^\circ C$ , **bold** values indicate  $-40^\circ C \leq T_J \leq +85^\circ C$ ; unless noted

SR	Slew Rate	voltage follower, 1V step, $R_L = 100k@0.9V$ $V_{OUT} = 1V_{P-P}$		0.015		V/ $\mu s$
GBW	Gain Bandwidth Product			25		kHz

## DC Electrical Characteristics (2.7V)

$V_{V+} = +2.7V$ ,  $V_{V-} = 0V$ ,  $V_{CM} = V_{OUT} = V_{V+}/2$ ;  $R_L = 1M$ ;  $T_J = 25^\circ C$ , **bold** values indicate  $-40^\circ C \leq T_J \leq +85^\circ C$ ; unless noted

Symbol	Parameter	Condition	Min	Typ	Max	Units
$V_{OS}$	Input Offset Voltage			0.9	7 <b>9</b>	mV mV
$TCV_{OS}$	Input Offset Voltage Temperature Drift			2.0		$\mu V/^\circ C$
$I_B$	Input Bias Current			1	10 <b>500</b>	pA pA
$I_{OS}$	Input Offset Current			0.01	0.5 <b>75</b>	pA pA
$R_{IN}$	Input Resistance			>10		$T\Omega$
+PSRR	Positive Power Supply Rejection Ratio	$2.7V \leq V_{V+} \leq 5V$ , $V_{V-} = 0V$ , $V_{CM} = V_{OUT} = 1.35V$	60	90		dB
-PSRR	Negative Power Supply Rejection Ratio	$-2.7V \leq V_{V-} \leq -5V$ , $V_{V+} = 0V$ , $V_{CM} = V_{OUT} = -1.35V$	60	90		dB
CMRR	Common-Mode Rejection Ratio	$V_{CM} = -0.2V$ to $+2.9V$	52	75		dB
$C_{IN}$	Common Mode Input Capacitance			3		pF
$V_{OUT}$	Output Voltage Swing	output high, $R_L = 100k$ , specified as $V_{V+} - V_{OUT}$		0.2	1 <b>1</b>	mV mV
		output low, $R_L = 100k$		0.2	1 <b>1</b>	mV mV
		output high, $R_L = 2k$ , specified as $V_{V+} - V_{OUT}$		10	33 <b>50</b>	mV mV
		output low, $R_L = 2k$		10	33 <b>50</b>	mV mV
$I_{SC}$	Output Short Circuit Current <b>Note 6</b>	sourcing, $V_{OUT} = 0V$	30	50		mA
		sinking, $V_{OUT} = 2.7V$	30	50		mA
$A_{VOL}$	Voltage Gain	sourcing		400		V/mV
		sinking		400		V/mV
$I_s$	Supply Current	$V_{V+} = 2.7V$ , $V_{OUT} = V_{V+}/2$		17	42	$\mu A$

## AC Electrical Characteristics (2.7V)

$V_+ = +2.7V$ ,  $V_- = 0V$ ,  $V_{CM} = V_{OUT} = V_{V+}/2$ ;  $R_L = 1M$ ;  $T_J = 25^\circ C$ , **bold** values indicate  $-40^\circ C \leq T_J \leq +85^\circ C$ ; unless noted

Symbol	Parameter	Condition	Min	Typ	Max	Units
SR	Slew Rate	voltage follower, 1V step, $R_L = 100k@1.35V$ $V_{OUT} = 1V_{P-P}$		0.015		V/ $\mu s$
GBW	Gain Bandwidth Product			25		kHz

## DC Electrical Characteristics (5V)

$V_{V+} = +5.0V$ ,  $V_{V-} = 0V$ ,  $V_{CM} = V_{OUT} = V_{V+}/2$ ;  $R_L = 1M$ ;  $T_J = 25^\circ C$ , **bold** values indicate  $-40^\circ C \leq T_J \leq +85^\circ C$ ; unless noted

Symbol	Parameter	Condition	Min	Typ	Max	Units
$V_{OS}$	Input Offset Voltage			0.9	7 <b>9</b>	mV mV
$TCV_{OS}$	Input Offset Voltage Temperature Drift			2.0		$\mu V/^\circ C$
$I_B$	Input Bias Current			1	10 <b>500</b>	pA pA
$I_{OS}$	Input Offset Current			0.01	0.5 <b>75</b>	pA pA
$R_{IN}$	Input Resistance			>10		$T\Omega$
+PSRR	Positive Power Supply Rejection Ratio	$5V \leq V_{V+} \leq 10V$ , $V_{V-} = 0V$ , $V_{CM} = V_{OUT} = 2.5V$	65	95		dB
-PSRR	Negative Power Supply Rejection Ratio	$-5V \leq V_{V-} \leq -10V$ , $V_{V+} = 0V$ , $V_{CM} = V_{OUT} = -2.5V$	65	95		dB
CMRR	Common-Mode Rejection Ratio	$V_{CM} = -0.2V$ to $+5.2V$	57	80		dB
$C_{IN}$	Common Mode Input Capacitance			3		pF
$V_{OUT}$	Output Voltage Swing	output high, $R_L = 100k$ , specified as $V_{V+} - V_{OUT}$		0.3	1.5 <b>1.5</b>	mV mV
		output low, $R_L = 100k$		0.3	1.5 <b>1.5</b>	mV mV
		output high, $R_L = 2k$ , specified as $V_{V+} - V_{OUT}$		15	50 <b>75</b>	mV mV
		output low, $R_L = 2k$		15	50 <b>75</b>	mV mV
$I_{SC}$	Output Short Circuit Current <b>Note 6</b>	sourcing, $V_{OUT} = 0V$	80	100		mA
		sinking, $V_{OUT} = 5V$	80	100		mA
$A_{VOL}$	Voltage Gain	sourcing		500		V/mV
		sinking		500		V/mV
$I_S$	Supply Current	$V_{V+} = 5V$ , $V_{OUT} = V_{V+}/2$		20	50	$\mu A$

## AC Electrical Characteristics (5V)

$V_{V+} = +5V$ ,  $V_{V-} = 0V$ ,  $V_{CM} = V_{OUT} = V_{V+}/2$ ;  $R_L = 1M$ ;  $T_J = 25^\circ C$ , **bold** values indicate  $-40^\circ C \leq T_J \leq +85^\circ C$ ; unless noted

Symbol	Parameter	Condition	Min	Typ	Max	Units
SR	Slew Rate	voltage follower, 1V step, $R_L = 100k@1.5V$ $V_{OUT} = 1V_{P-P}$		0.02		V/ $\mu s$
GBW	Gain Bandwidth Product			25		kHz

## DC Electrical Characteristics (10V)

$V_{V+} = +10V$ ,  $V_{V-} = 0V$ ,  $V_{CM} = V_{OUT} = V_{V+}/2$ ;  $R_L = 1M$ ;  $T_J = 25^\circ C$ , **bold** values indicate  $-40^\circ C \leq T_J \leq +85^\circ C$ ; unless noted

Symbol	Parameter	Condition	Min	Typ	Max	Units
$V_{OS}$	Input Offset Voltage			0.9	7 <b>9</b>	mV mV
$TCV_{OS}$	Input Offset Voltage Temperature Drift			2.0		$\mu V/^\circ C$

Symbol	Parameter	Condition	Min	Typ	Max	Units
$I_B$	Input Bias Current			1	10 <b>500</b>	pA pA
$I_{OS}$	Input Offset Current			0.01	0.5 <b>75</b>	pA pA
$R_{IN}$	Input Resistance			>10		$T\Omega$
+PSRR	Positive Power Supply Rejection Ratio	$5V \leq V_{V+} \leq 10V$ , $V_{V-} = 0V$ , $V_{CM} = V_{OUT} = 2.5V$	65	95		dB
-PSRR	Negative Power Supply Rejection Ratio	$-5V \leq V_{V-} \leq -10V$ , $V_{V+} = 0V$ , $V_{CM} = V_{OUT} = -2.5V$	65	95		dB
CMRR	Common-Mode Rejection Ratio	$V_{CM} = -0.2V$ to $+10.2V$	60	85		dB
$C_{IN}$	Common Mode Input Capacitance			3		pF
$V_{OUT}$	Output Voltage Swing	output high, $R_L = 100k$ , specified as $V_{V+} - V_{OUT}$		0.45	2.5 <b>2.5</b>	mV mV
		output low, $R_L = 100k$		0.45	2.5 <b>2.5</b>	mV mV
		output high, $R_L = 2k$ , specified as $V_{V+} - V_{OUT}$		24	80 <b>120</b>	mV mV
		output low, $R_L = 2k$		24	80 <b>120</b>	mV mV
$I_{SC}$	Output Short Circuit Current <b>Note 6</b>	sourcing, $V_{OUT} = 0V$	100	200		mA
		sinking, $V_{OUT} = 10V$	100	200		mA
$A_{VOL}$	Voltage Gain	sourcing		500		V/mV
		sinking		500		V/mV
$I_S$	Supply Current	$V_{V+} = 10V$ , $V_{OUT} = V_{V+}/2$		25	65	$\mu A$

## AC Electrical Characteristics (10V)

$V_+ = +10V$ ,  $V_- = 0V$ ,  $V_{CM} = V_{OUT} = V_{V+}/2$ ;  $R_L = 1M$ ;  $T_J = 25^\circ C$ , **bold** values indicate  $-40^\circ C \leq T_J \leq +85^\circ C$ ; unless noted

Symbol	Parameter	Condition	Min	Typ	Max	Units
SR	Slew Rate	voltage follower, 1V step, $R_L = 100k@1.35V$ $V_{OUT} = 1V_{P-P}$		0.02		V/ $\mu s$
GBW	Gain Bandwidth Product			25		kHz
$\phi_M$	Phase Margin			50		$^\circ$
$G_M$	Gain Margin			15		dB
$e_N$	Input Referred Voltage Noise	$f = 1kHz$ , $V_{CM} = 1.0V$		110		$nV/\sqrt{Hz}$
$i_N$	Input Referred Current Noise	$f = 1kHz$		0.03		$pA/\sqrt{Hz}$

**General Notes:** Devices are ESD protected; however, handling precautions are recommended. All limits guaranteed by testing on statistical analysis.

**Note 1:** Absolute maximum ratings indicate limits beyond which damage to the component may occur. Electrical specifications do not apply when operating the device outside its recommended operating ratings.

**Note 2:** I/O Pin Voltage is any external voltage to which an input or output is referenced.

**Note 3:** The maximum allowable power dissipation is a function of the maximum junction temperature,  $T_{J(max)}$ ; the junction-to-ambient thermal resistance,  $\theta_{JA}$ ; and the ambient temperature,  $T_A$ . The maximum allowable power dissipation at any ambient temperature is calculated using:  $P_D = (T_{J(max)} - T_A) \div \theta_{JA}$ . Exceeding the maximum allowable power dissipation will result in excessive die temperature.

**Note 4:** Thermal resistance,  $\theta_{JA}$ , applies to a part soldered on a printed-circuit board.

**Note 5:** Human body model, 1.5k in series with 100pF.

**Note 6:** Short circuit may cause the device to exceed maximum allowable power dissipation. See **Note 3**.

## Application Information

### Input Common-Mode Voltage

The MIC7111 tolerates input overdrive by at least 300mV beyond either rail without producing phase inversion.

If the absolute maximum input voltage is exceeded, the input current should be limited to  $\pm 5\text{mA}$  maximum to prevent reducing reliability. A  $10\text{k}\Omega$  series input resistor, used as a current limiter, will protect the input structure from voltages as large as 50V above the supply or below ground. See Figure 1.

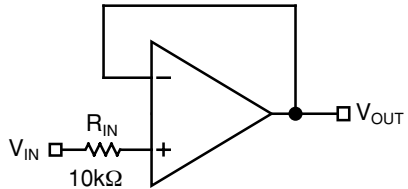


Figure 1. Input Current-Limit Protection

### Output Voltage Swing

Sink and source output resistances of the MIC7111 are equal. Maximum output voltage swing is determined by the load and the approximate output resistance. The output resistance is:

$$R_{\text{OUT}} = \frac{V_{\text{DROP}}}{I_{\text{LOAD}}}$$

$V_{\text{DROP}}$  is the voltage dropped within the amplifier output stage.  $V_{\text{DROP}}$  and  $I_{\text{LOAD}}$  can be determined from the  $V_{\text{O}}$  (output swing) portion of the appropriate Electrical Characteristics table.  $I_{\text{LOAD}}$  is equal to the typical output high voltage minus  $V_{+}/2$  and divided by  $R_{\text{LOAD}}$ . For example, using the Electrical Characteristics DC (5V) table, the typical output voltage drop using a  $2\text{k}\Omega$  load (connected to  $V_{+}/2$ ) is 0.015V, which produces an  $I_{\text{LOAD}}$  of:

$$\frac{2.5\text{V} - 0.015\text{V}}{2\text{k}\Omega} = 1.243\text{mA}$$

then:

$$R_{\text{OUT}} = \frac{15\text{mV}}{1.243\text{mA}} = 12.1 \approx 12\Omega$$

### Driving Capacitive Loads

Driving a capacitive load introduces phase-lag into the output signal, and this in turn reduces op-amp system phase margin. The application that is least forgiving of reduced phase margin is a unity gain amplifier. The MIC7111 can typically drive a 500pF capacitive load connected directly to the output when configured as a unity-gain amplifier.

### Using Large-Value Feedback Resistors

A large-value feedback resistor ( $> 500\text{k}\Omega$ ) can reduce the phase margin of a system. This occurs when the feedback resistor acts in conjunction with input capacitance to create phase lag in the feedback signal. Input capacitance is usually a combination of input circuit components and other parasitic capacitance, such as amplifier input capacitance and stray printed circuit board capacitance.

Figure 2 illustrates a method of compensating phase lag caused by using a large-value feedback resistor. Feedback capacitor  $C_{\text{FB}}$  introduces sufficient phase lead to overcome the phase lag caused by feedback resistor  $R_{\text{FB}}$  and input capacitance  $C_{\text{IN}}$ . The value of  $C_{\text{FB}}$  is determined by first estimating  $C_{\text{IN}}$  and then applying the following formula:

$$R_{\text{IN}} \times C_{\text{IN}} \leq R_{\text{FB}} \times C_{\text{FB}}$$

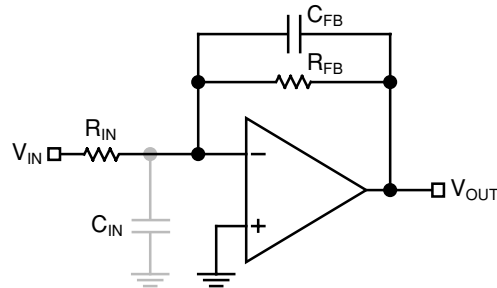


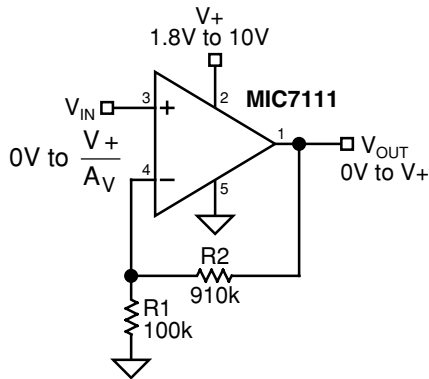
Figure 2. Cancelling Feedback Phase Lag

Since a significant percentage of  $C_{\text{IN}}$  may be caused by board layout, it is important to note that the correct value of  $C_{\text{FB}}$  may

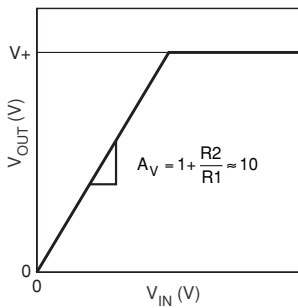
change when changing from a breadboard to the final circuit layout.

**Typical Circuits**

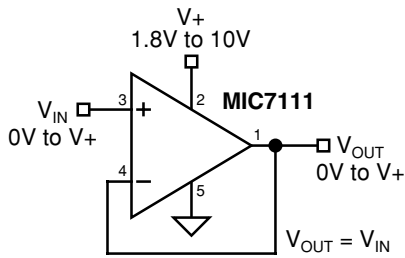
Some single-supply, rail-to-rail applications for which the MIC7111 is well suited are shown in the circuit diagrams of Figures 3 through 7.



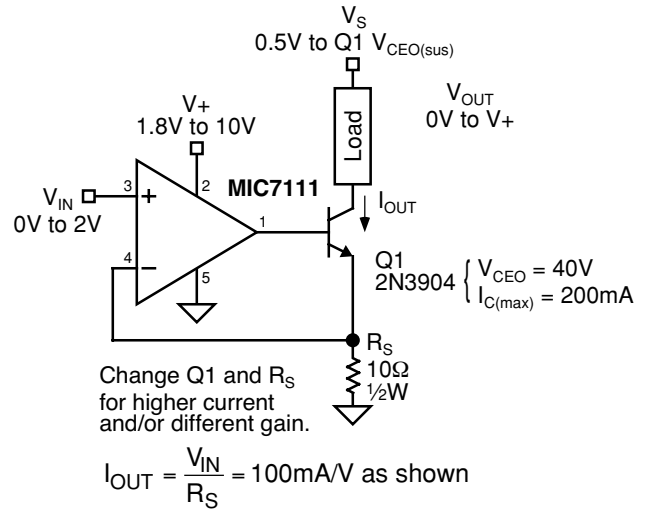
**Figure 3a. Noninverting Amplifier**



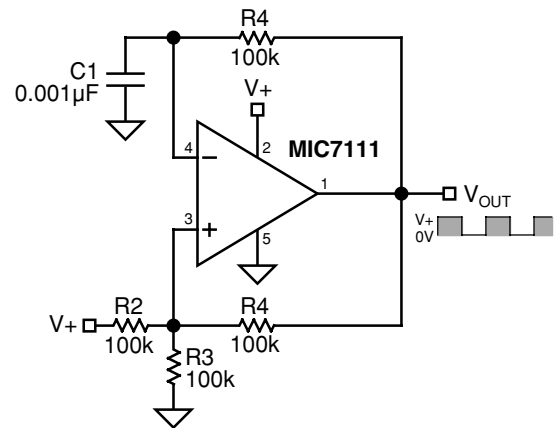
**Figure 3b. Noninverting Amplifier Behavior**



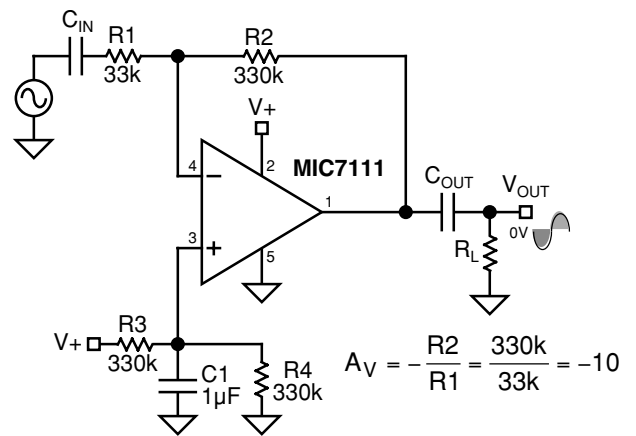
**Figure 4. Voltage Follower/Buffer**



**Figure 5. Voltage-Controlled Current Sink**

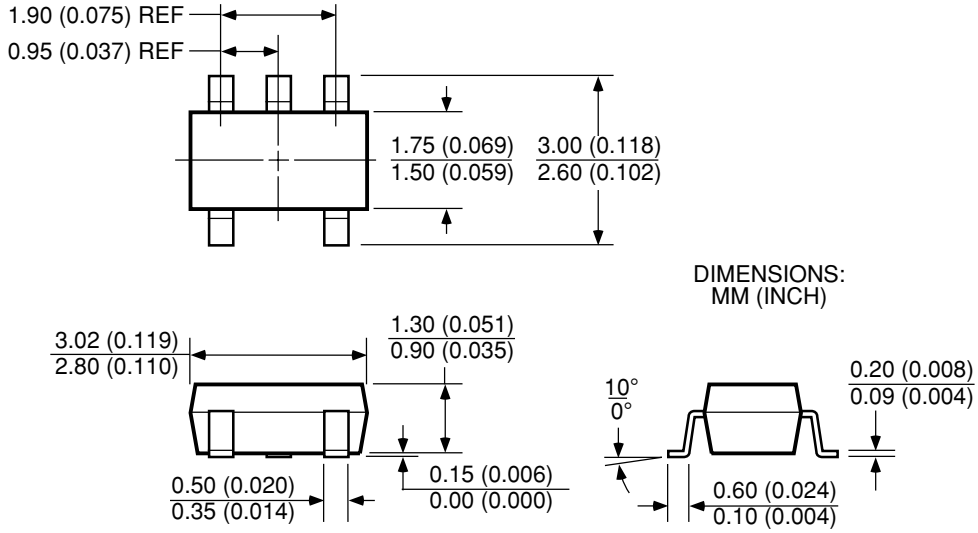


**Figure 6. Square Wave Oscillator**



**Figure 7. AC-Coupled Inverting Amplifier**

Package Information



SOT-23-5 (M5)

MICREL INC. 1849 FORTUNE DRIVE SAN JOSE, CA 95131 USA

TEL + 1 (408) 944-0800 FAX + 1 (408) 944-0970 WEB <http://www.micrel.com>

This information is believed to be accurate and reliable, however no responsibility is assumed by Micrel for its use nor for any infringement of patents or other rights of third parties resulting from its use. No license is granted by implication or otherwise under any patent or patent right of Micrel Inc.

© 2005 Micrel Incorporated